



INTERFACE CONTROL DOCUMENT

PAR36 LED TAXI LIGHT 20 Kcd

P/N: 6490786 AMD(0)



Diffusion	Interne à JPC			Externe à JPC	
	1 ex →			1 ex → EASA	
Version	Document	Issue	Date	Last evolution	
	649 07 86 ICD 01	<u>2</u>	<u>11/02/2019</u>	<u>See page 2</u>	
Visas	Author : Julien Bonneau		Technical : Julien Bonneau / Pierre Jacquier		Approbation : Christian Escoto
					 <p>SAS au capital de 142800€ Aérodrome Dijon-Darois 21121-DAROIS-FRANCE Siret: 334 625 738 00029 TVA: FR 73 334 625 738</p>

TABLE OF CONTENTS

1	General	4
1.1	Generalities	4
1.2	Destination	4
1.3	Description	4
2	Physical, electrical and optical features	5
2.1	Physical features	5
2.2	Electrical interface	5
2.3	Electrical power supply	5
2.4	Power dissipation	5
2.5	Optical features	5
2.6	Operating temperature	5
3	3D views	6
4	Installation procedure	7
5	Periodic Inspections	8
6	2D Drawing	9

1 General

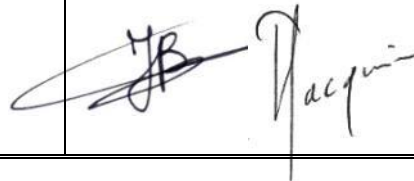
1.1 Generalities

This document defines the electrical, mechanical and thermal interfaces and the installation procedure of the equipment "PAR36 Led Taxi Light", P/N 6490786 amd(0).

1.2 Destination

Aircraft, rotorcraft, General Aviation.

1.3 Description

PAR36 Led Taxi Light is designed to provide enough light for night operations, with no dangerous glare or halation visible to the pilots.

The Led Taxi Light aims to produce a white light in accordance with CS 23.1383 requirements.

The source of light is made up of 5 white Leds diodes equipped with conical collimator.

The Leds diodes type is SMD LED 10 Watt with 120 °distribution, with high performances, identical to that already used in our strobe and anti-collision lights certified CS25 or CS29 for planes and helicopters.

The shape, mechanical interface, weight and electrical interface are preserved compared to incandescent Taxi lights currently installed.

This design offers an extremely high reliability, a high resistance to shocks and vibration.

Positive points of this new equipment:

- Shape, electrical interface, weight and mechanics interface preserved.
- 20.000 hours MTBF.
- No high heat in the equipment.

2 Physical, electrical and optical features

2.1 Physical features

- Individual weight : 315 g +/- 10 %
- Dimensions : see 2D drawing in §6
- Number of LEDs : 5 white Leds
- Envelope color : Aluminum with SURTEC 650 treatment

2.2 Electrical interface

2 PC screw terminal - Screws 6-32 x 6.5 (3.5 x 6.5)
See 2D drawing for polarity.
For standard crimp ring terminal 4mm.

2.3 Electrical power supply

- Supply Voltage : 28 V DC (DO 160 D)
Same performances from 24 V to 32 V
- Current : 2.4 A +/- 20 % at 28 V

Performances In other situations (24, 26, 28 and 32 V):

Power supply level (in Volts)	Current	Performances
24 V	2.8 A	Preserved
26 V	2.6 A	Preserved
28 V	2.4 A	Normal
32 V	2.1 A	Preserved

2.4 Power dissipation

Power dissipation average	38 W
---------------------------	------

Internal fan. Permanent forced air cooling.
Internal overheat protection

2.5 Optical features

- 5 high power white Leds CREE.
- Collimators: 46,8° horizontal x 10,3° vertical.
- Light intensity in accordance with CS-23 requirements.

2.6 Operating temperature

- Positive temperature : +70°C
- Negative temperature : - 45°C

3 3D views

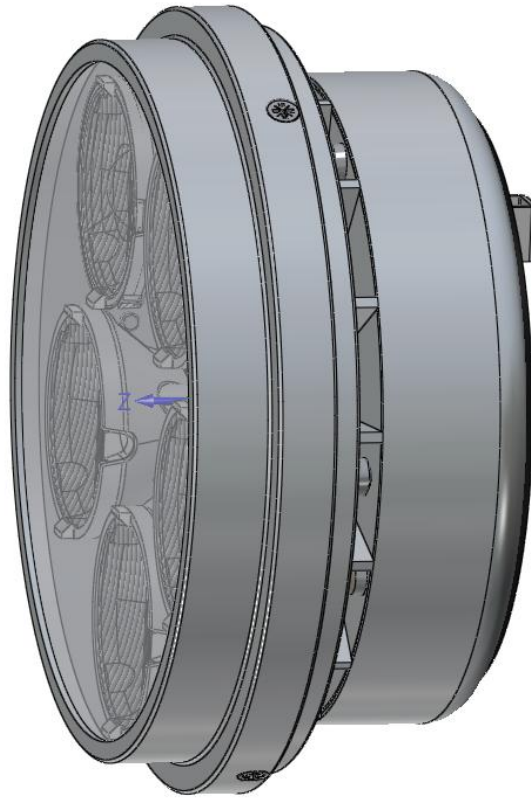

4 Installation procedure

The following information provides guidelines for the installation of the PAR36 LED TAXI LIGHT.
Please refer to the OEM manual of the aircraft for specific removal and installation instructions.

- Connect the supply wires on the two PC screw terminal of the equipment. Respect following polarity:

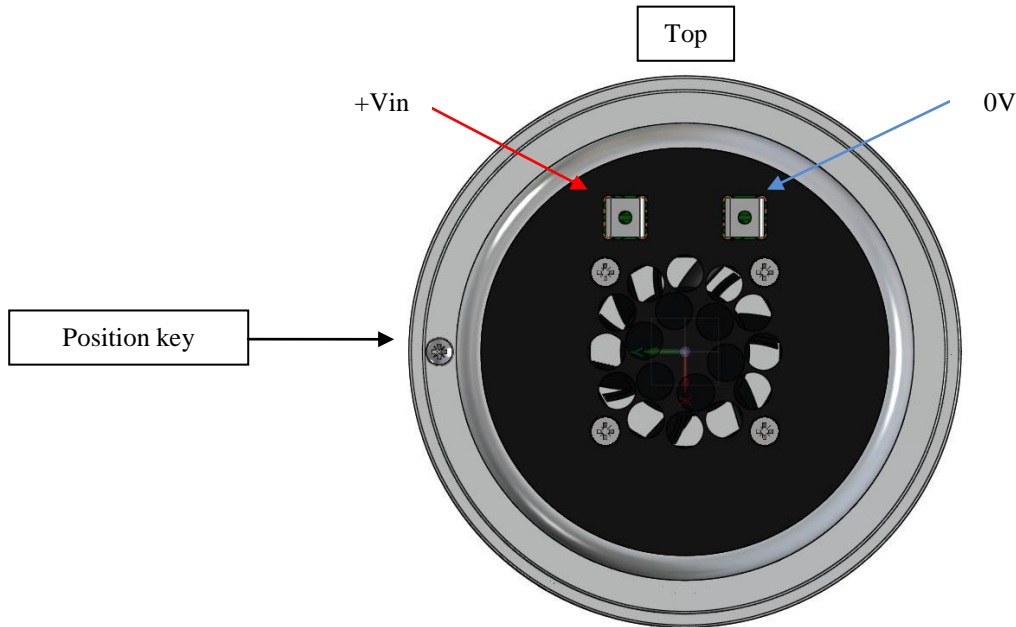

- Place the equipment in the aircraft mounting part (see pictures below for example)
If available, ensure that the position key (see 2D Drawing in § 6) of the equipment matches with the key of the aircraft mounting part.

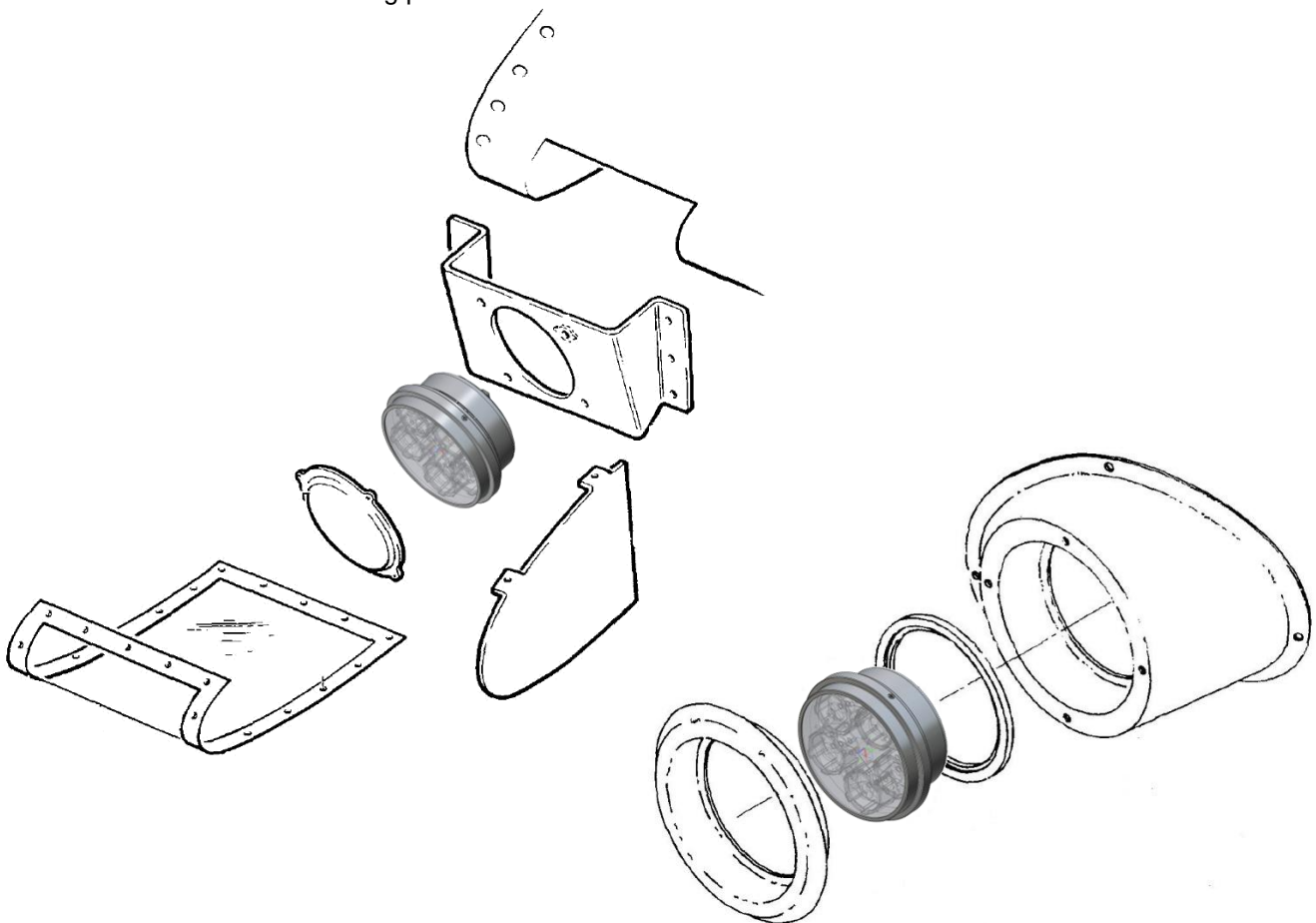

5 Periodic Inspections

Every 100 hours or annually:

- Check that all Leds are illuminated.
WARNING: Due to the high light intensity emitted by the equipment, it is recommended to wear eyes protection.
- Check the glass aspect (absence of stripe or cracking)
- Check the good state of the mechanical assembly and the electrical connections.

6 2D Drawing

