



INTERFACE CONTROL DOCUMENT

PAR36 LED TAXI LIGHT

P/N: 6490775 AMD(0)



Diffusion	Interne à JPC			Externe à JPC	
	1 ex →			1 ex → EASA	
Version	Document	Issue.	Date	Last evolution	Pages changed
	649 07 75 ICD 01	<u>5</u>	<u>22/02/2019</u>	See page 2	all
Visas	Author : Julien Bonneau		Technical : Julien Bonneau / Pierre Jacquier		Approbation : Christian Escoto
					

TABLE OF CONTENTS

1	<i>General</i>	4
1.1	Generalities	4
1.2	Destination	4
1.3	Description	4
2	<i>Physical, electrical and optical features</i>	5
2.1	Physical features	5
2.2	Electrical interface	5
2.3	Electrical power supply	5
2.4	Power dissipation	5
2.5	Optical features	5
2.6	Operating temperature	5
3	<i>3D views</i>	6
4	<i>Installation procedure</i>	7
5	<i>Periodic Inspections</i>	8
6	<i>2D Drawing</i>	9

1 General

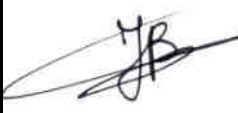
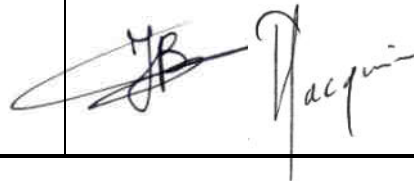
1.1 Generalities

This document defines the electrical, mechanical and thermal interfaces and the installation procedure of the equipment "PAR36 Led Taxi Light", P/N 6490775 amd(0).

1.2 Destination

Aircraft of General Aviation.

1.3 Description

PAR36 Led Taxi Light is designed to provide enough light for night operations, with no dangerous glare or halation visible to the pilots.

The Led Taxi Light aims to produce a white light in accordance with CS 23.1383 requirements.

The source of light is made up of 12 white diodes equipped with conical collimator.

The Leds diodes type is SMD LED 1 Watt with 120 °distribution, with high performances, identical to that already used in our strobe and anti-collision lights certified CS25 or CS29 for planes and helicopters.

The shape, mechanical interface, weight and electrical interface are preserved compared to incandescent Taxi lights currently installed.

This design offers an extremely high reliability, a high resistance to shocks and vibration.

Positive points of this new equipment:

- Shape, electrical interface, weight and mechanics interface preserved.
- 20.000 hours MTBF.
- No high heat in the equipment.

2 Physical, electrical and optical features

2.1 Physical features

- Individual weight : 210 g +/- 10 %
- Dimensions : see 2D drawing in §6
- Number of LEDs : 12 white Leds
- Envelope color : Aluminum with SURTEC 650 protection

2.2 Electrical interface

2 PC screw terminal - Screws 6-32 x 6.5 (3.5 x 6.5)

No polarity.

For standard crimp ring terminal 4mm.

2.3 Electrical power supply

- Supply Voltage : 14 / 28 V DC (DO 160 D, cat A)
Same performances from 12 V to 32 V
- Current : 1.2 A +/- 10 % at 14 V
0.62 A +/- 10 % at 28 V

Performances In other situations (18, 21, 28 and 32 V):

Power supply level (in Volts)	Current	Performances
12 V	1.5 A	Preserved
14 V	1.2 A	Normal
16 V	1.1 A	Preserved
24 V	0.75 A	Preserved
28 V	0.62 A	Normal
32 V	0.55 A	Preserved

2.4 Power dissipation

Power dissipation average	8 W
---------------------------	-----

2.5 Optical features

- 12 high power white Leds CREE.
- Collimators: 54°x 9°
- Light intensity in accordance with CS-23 requirements.

2.6 Operating temperature

- Positive temperature : +70°C
- Negative temperature : - 45°C

3 3D views



|

4 Installation procedure

The following information provides guidelines for the installation of the PAR36 LED TAXI LIGHT. Please refer to the OEM manual of the aircraft for specific removal and installation instructions.

- Connect the supply wires on the two PC screw terminal (no polarity) of the equipment.

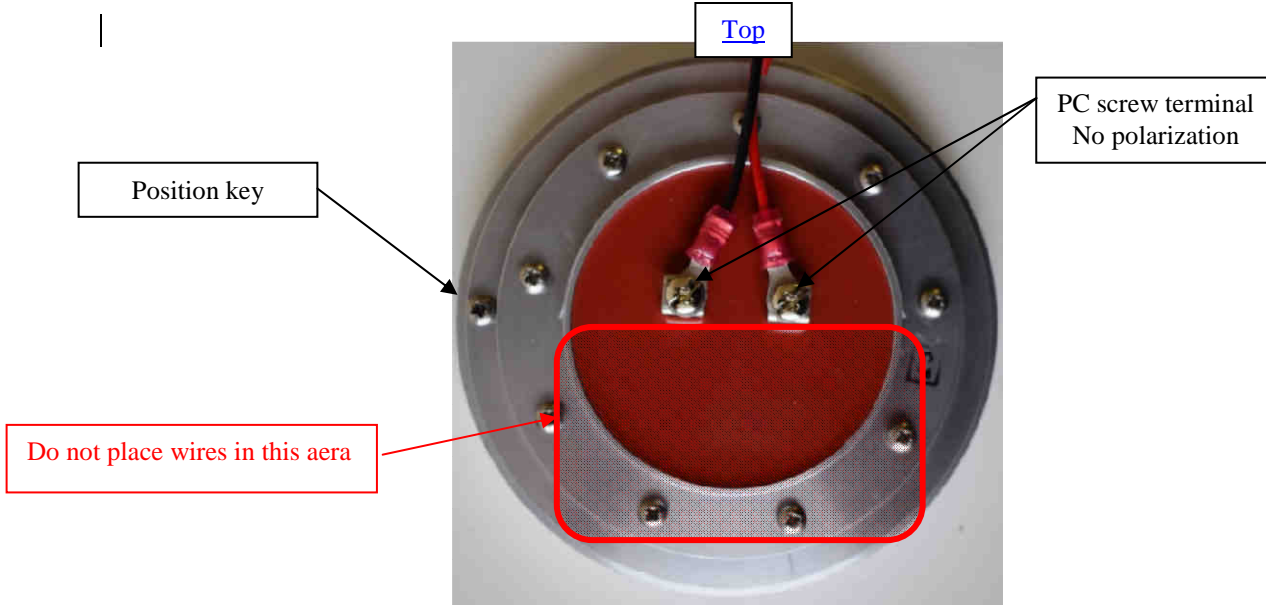

- Place the equipment in the aircraft mounting part (see picture below). If available, ensure that the position key (see 2D Drawing in § 6) of the equipment matches with the key of the aircraft mounting part. If not available, orient the equipment so that the collimators streaks should be orientated **vertically** to produce a horizontal light beam.

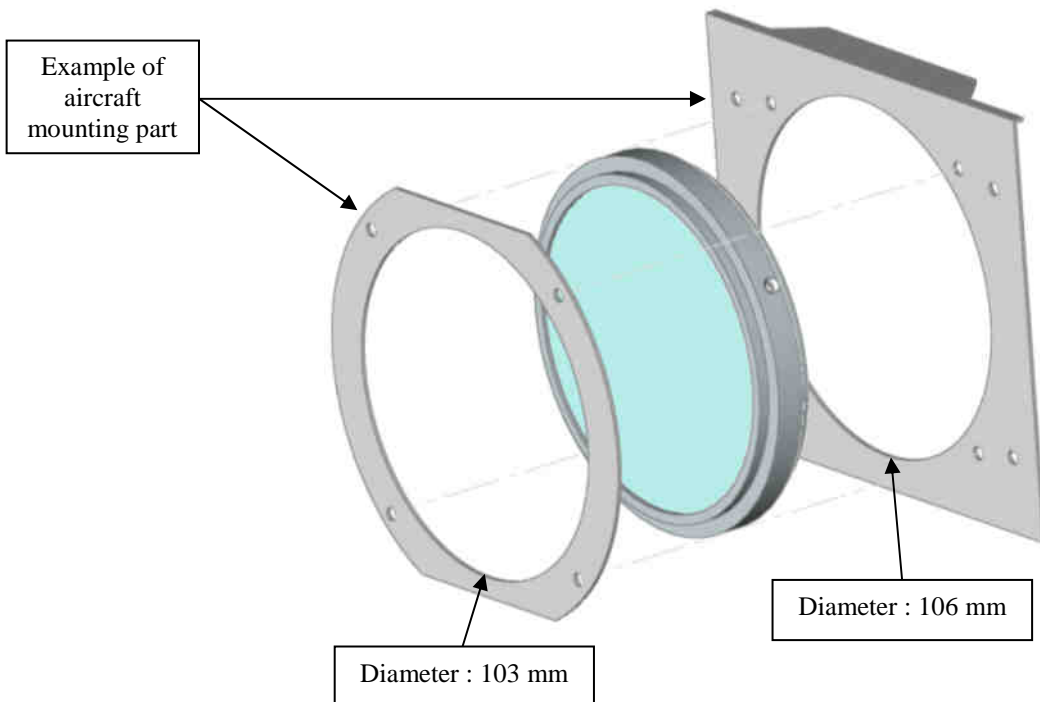

- Tighten the aircraft mounting part on the equipment to hold it in position.



5 Periodic Inspections

Every 100 hours or annually:

- Check that all Leds are illuminated.
WARNING: Due to the high light intensity emitted by the equipment, it is recommended to wear eyes protection.
- Check the glass aspect (absence of stripe or cracking)
- Check the good state of the mechanical assembly and the electrical connections.

6 2D Drawing

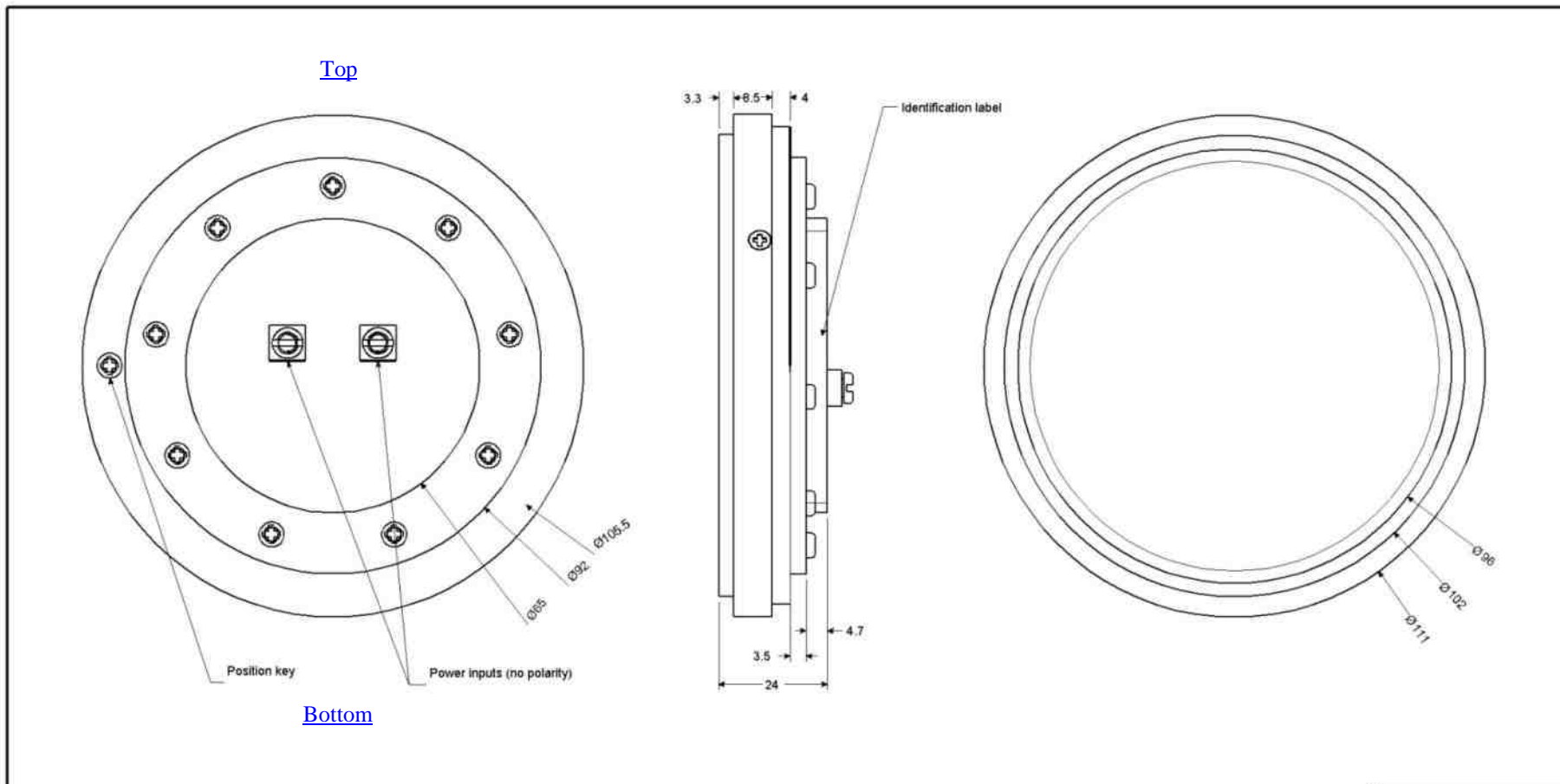

PAGE : 1/1

PIECE	PLAN	x	MATIERE :	Tolérance cotes et angles (sauf si spécifiè) : 1/10°
Modif N° :	Date	MODIFICATION		Indice
Ce plan est la propriété de JPC AVIATION et ne peut être reproduit ou communiqué sans notre accord				
Dessiné par : Christian Escoto le 16/12/2016				JPC AVIATION Equipements Aéronautiques 21121 DAROIS - FRANCE
Vérifié par : _____ Le : _____				
Echelle : 1	Ref. Piece : _____	Code ATA 100 : _____		N° : 649 07 75 FD 02-00
DESIGNATION : PAR 36 LED TAXI LIGHT - 2D DRAWING				