



## INTERFACE CONTROL DOCUMENT

### SHORT LED ANTICOLLISION LIGHT



#### RED SHORT LED ANTICOLLISION LIGHT

P/N: 6487400 AMD([A](#))

#### WHITE SHORT LED ANTICOLLISION LIGHT

P/N: 6487500 AMD([A](#))

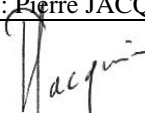
### CS-ETSO C96b

<b>Diffusion</b>	<b>Interne à JPC</b>			<b>Externe à JPC</b>	
	1 ex → RAQ			1 ex → EASA	
<b>Version</b>	<b>Document</b>	<b>Issue</b>	<b>Date</b>	<b>Last evolution</b>	<b>Pages changed</b>
	648 74&75 00 ICD 01	<a href="#">3</a>	<a href="#">10/03/2022</a>	<a href="#">See page 2</a>	<a href="#">All</a>
<b>Visas</b>	<b>Author : Julien BONNEAU</b>		<b>Technical : Pierre JACQUIER</b>		<b>Approbation : Christian ESCOTO</b>
					



## Table of contents

<b>1</b>	<b><i>General</i></b>	<b>4</b>
1.1	Generalities	4
1.2	Destination	4
1.3	Related documents	4
1.4	Description	4
1.4.1	Red Short Led Anticollision Light P/N 6487400 AMD(A)	4
1.4.2	White Short Led Anticollision Light P/N 6487500 AMD(A)	4
<b>2</b>	<b><i>Mechanical interfaces</i></b>	<b>5</b>
2.1	Equipment outlines	5
2.2	Mounting	5
<b>3</b>	<b><i>Optical features</i></b>	<b>6</b>
3.1.1	Red Short Led Anticollision Light P/N 6487400	6
3.1.2	White Short Led Anticollision Light P/N 6487500	6
<b>4</b>	<b><i>Operating temperature</i></b>	<b>6</b>
<b>5</b>	<b><i>Electrical interfaces</i></b>	<b>7</b>
5.1	Power supply interface	7
5.1.1	Red Short Led Anticollision Light P/N 6487400	7
5.1.2	White Short Led Anticollision Light P/N 6487500	7
5.2	Power dissipation	8
5.3	Signals and wires definition	8
5.4	Grounding and bonding	8
<b>6</b>	<b><i>Installation procedure</i></b>	<b>9</b>
6.1	Direct mounting without adaptation flange	9
6.2	Mounting with adaptation flange	9
6.3	Limitation	10
<b>7</b>	<b><i>Periodic Inspections</i></b>	<b>10</b>
<b>8</b>	<b><i>Annex 1 - 3D view</i></b>	<b>11</b>
8.1	3D view (direct mounting with M5 Screw)	11
8.2	3D view with adaptation flange P/N 514 314	11
<b>9</b>	<b><i>Annex 2 – 2D drawing</i></b>	<b>12</b>
9.1	2D view (direct mounting with M5 Screw)	12
9.2	2D view with adaptation flange P/N 514 314 for classic interface mounting	13

## 1 General

### 1.1 Generalities

This document defines the electrical, mechanical and thermal interfaces for RED and WHITE SHORT LED ANTICOLLISION LIGHT.

Equipment and accessories designation	Supplier	Part Number
RED SHORT LED ANTICOLLISION LIGHT	JPC AVIATION	6487400
WHITE SHORT LED ANTICOLLISION LIGHT	JPC AVIATION	6487500

### 1.2 Destination

Fixed wing aircraft (CS23) and rotorcraft (CS27)

### 1.3 Related documents

See last evolution of Design & Description File 648 74&75 00 DF 01.

### 1.4 Description

#### 1.4.1 Red Short Led Anticollision Light P/N 6487400 AMD(A)

The Short Red Led Anticollision Light aims to produce flashing light in accordance to CS-ETSO:

Classification following SAE AS 8017C: CLASS I (Rotorcrafts) or CLASS III (Fixed Wing Aircraft and Rotorcraft)

The source of light is made up of 18 red diodes leds associated, and broken down by sector of 2 leds positioned at 40°.

The led in down side of each sector is equipped with an elliptic collimator.

The Leds diodes type is SMD LED 1 Watt with 120 ° distribution and high performances, identical to that already used in our others anti-collision lights certified CS-ETSO, CS25 on Dassault Falcon or CS27/29 on Airbus helicopters.

The Short Led Anticollision Light includes electronic system with current regulation, the flashing command and EMI/EMC protections. This design offers an extremely high reliability, a high resistance to shocks and vibration.

Fixation by central M5 screw (delivered with anticollision light)

An adaptation flange P/N 514 314 can be provide separately for direct mounting on classic 4 holes interfaces.

#### 1.4.2 White Short Led Anticollision Light P/N 6487500 AMD(A)

The Short White Led Anticollision Light aims to produce flashing light in accordance to CS-ETSO:

Classification following SAE AS 8017C: CLASS III (Fixed Wing Aircraft and Rotorcraft)

The source of light is made up of 18 white diodes leds associated, and broken down by sector of 2 leds positioned at 40°.

The led in down side of each sector is equipped with an elliptic collimator.

The Leds diodes type is SMD LED 1 Watt with 120 ° distribution and high performances, identical to that already used in our others anti-collision lights certified CS-ETSO, CS25 on Dassault Falcon or CS27/29 on Airbus helicopters.

The Short Led Anticollision Light includes electronic system with current regulation, the flashing command and EMI/EMC protections. This design offers an extremely high reliability, a high resistance to shocks and vibration.

Fixation by central M5 screw (delivered with anticollision light)

An adaptation flange P/N 514 314 can be provide separately for direct mounting on classic 4 holes interfaces.

## 2 Mechanical interfaces

### 2.1 Equipment outlines

Same characteristic for Red & White ACL

- Weight : 125 g +/- 10 %.
- Dimensions : see 2D drawing in annex.
- Led : 18 red/orange Leds CREE XP-E2 for Red Short ACL  
18 white leds CREE XP-E2 for White Short ACL
- Lens : polycarbonate with "UV" protection.
- Mechanical part : Aluminum 2017 with SURTEC 650 protection
  
- Adaptation flange P/N 514 314 (optional)  
Flange weight : 19 g +/- 10%

### 2.2 Mounting

See interface drawing in annex.

### 3 Optical features

#### 3.1.1 Red Short Led Anticollision Light P/N 6487400

- 18 high power red/orange Leds CREE XP-E2.
- Led : Diffusion angle 120°.
- Led luminous flux : 107 lumens at 350 mA.
- Light Intensity:

According to SAE AS 8017C CLASS I (Rotorcraft):

Light intensity : 150 candelas

Horizontal distribution : 360 °

Vertical distribution:

Angle above & below horizontal plane	Ie (candle)
0° à 5°	>150
5° à 10°	> 90
10° à 20°	> 30
20° à 30°	> 15

According to SAE AS 8017C CLASS III (Fixed Wing Aircraft and Rotorcraft):

Light intensity : 100 candelas

Horizontal distribution : 360 °

Vertical distribution:

Angle above & below horizontal plane	Ie (candle)
0° à 5°	>100
5° à 10°	> 60
10° à 20°	> 20
20° à 30°	> 10

#### 3.1.2 White Short Led Anticollision Light P/N 6487500

- 18 high power white Leds CREE XP-E2.
- Led : Diffusion angle 120°.
- Led luminous flux : 122 lumens at 350 mA.
- Light Intensity:

According to SAE AS 8017C CLASS III (Fixed Wing Aircraft and Rotorcraft):

Light intensity : 100 candelas

Horizontal distribution : 360 °

Vertical distribution:

Angle above & below horizontal plane	Ie (candle)
0° à 5°	>100
5° à 10°	> 60
10° à 20°	> 20
20° à 30°	> 10

### 4 Operating temperature

Positive temperature : +70 °C.

Negative temperature : - 45 °C.

## 5 Electrical interfaces

### 5.1 Power supply interface

#### 5.1.1 Red Short Led Anticollision Light P/N 6487400

3 free end G22 wires    Red wire           :        +Vin  
                                   Black wire       :        0V  
                                   White wire      :        Reduce mode (5%) if linked at +Vin

- Supply Voltage            :        11 to 32 V
- Peak current              :        0.7 A peak current at 28 V  
                                   1.3 A peak current at 14 V
- Power                      :        5.9 Watt average
- Leds current              :        350 mA Internal led regulation (12.6 Watt for a VF of 4V)
- Lamp time ON            :        1er flash                    :        250 ms  
                                   2nd flash                    :        125 ms
- Rating                    :        0.8 Hertz (+/- 5 %)

Performances In other situations (11, 16, 24 and 32 V):

Power supply level (in Volts )	Peak Current	Performances
11 V	1.65 A	Preserved
14 V	1.3 A	Normal
16 V	1.14 A	Preserved
24 V	0.79 A	Preserved
28 V	0.7 A	Normal
32 V	0.6 A	Preserved

#### 5.1.2 White Short Led Anticollision Light P/N 6487500

3 free end G22 wires    Red wire           :        +Vin  
                                   Black wire       :        0V  
                                   White wire      :        Reduce mode (5%) if linked at +Vin

- Supply Voltage            :        11 to 32 V
- Peak current              :        0.7 A peak current at 28 V  
                                   1.3 A peak current at 14 V
- Power                      :        5.9 Watt average
- Leds current              :        250 mA Internal led regulation (12.6 Watt for a VF of 5.6 V)
- Lamp time ON            :        1er flash                    :        250 ms  
                                   2nd flash                    :        125 ms
- Rating                    :        0.8 Hertz (+/- 5 %)

Performances In other situations (11, 16, 24 and 32 V):

Power supply level (in Volts )	Peak Current	Performances
11 V	1.65 A	Preserved
14 V	1.3 A	Normal
16 V	1.14 A	Preserved
24 V	0.79 A	Preserved
28 V	0.7 A	Normal
32 V	0.6 A	Preserved

### 5.2 Power dissipation

Same characteristic for Red & White ACL	
Operating Mode	Power dissipation MAX
ON	3.8 W
OFF	0 W

### 5.3 Signals and wires definition

Same characteristic for Red & White ACL

3 free end G22 wires	Red wire	:	+Vin
	Black wire	:	0V
	White wire	:	Reduce mode (5%) if linked at +Vin

### 5.4 Grounding and bonding

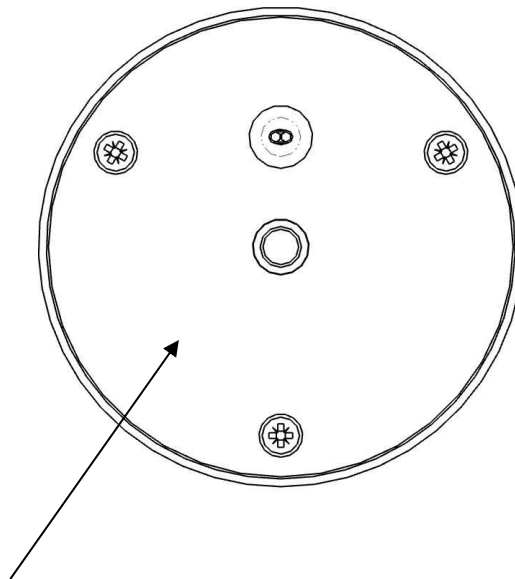

Bottom metalized area



## 6 Installation procedure

The following information provides guidelines for the installation of SHORT LED ANTICOLLISION LIGHTS. Please refer to the OEM manual of the aircraft for specific removal and installation instructions.

### 6.1 Direct mounting without adaptation flange

- Connect the supply wires (see polarity in §5.1.2) of the equipment.
- Direct mounting with CHC M5x50 Screw (included) with threadlocker (example: LOCTITE 243)
- Recommended torque: 3 Nm

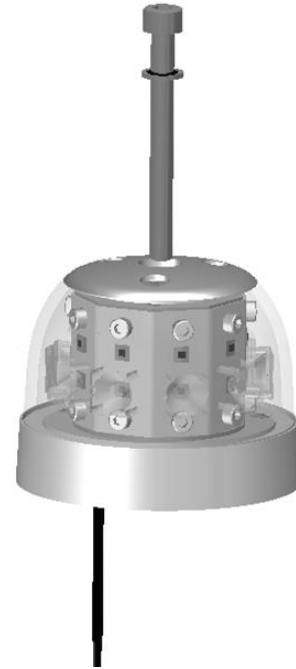
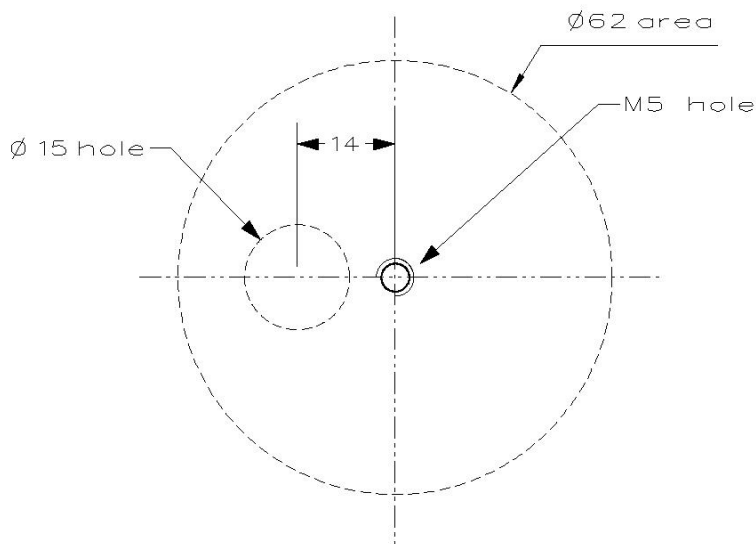

### 6.2 Mounting with adaptation flange

- Put in place the flange P/N 514 314 and fix with 4 x M3 or 6.32 screws
- Connect the supply wires (see polarity in §5.1.2) of the equipment.
- Fix ACL with CHC M5x50 Screw (included) with threadlocker (example: LOCTITE 243)
- Recommended torque: 3 Nm

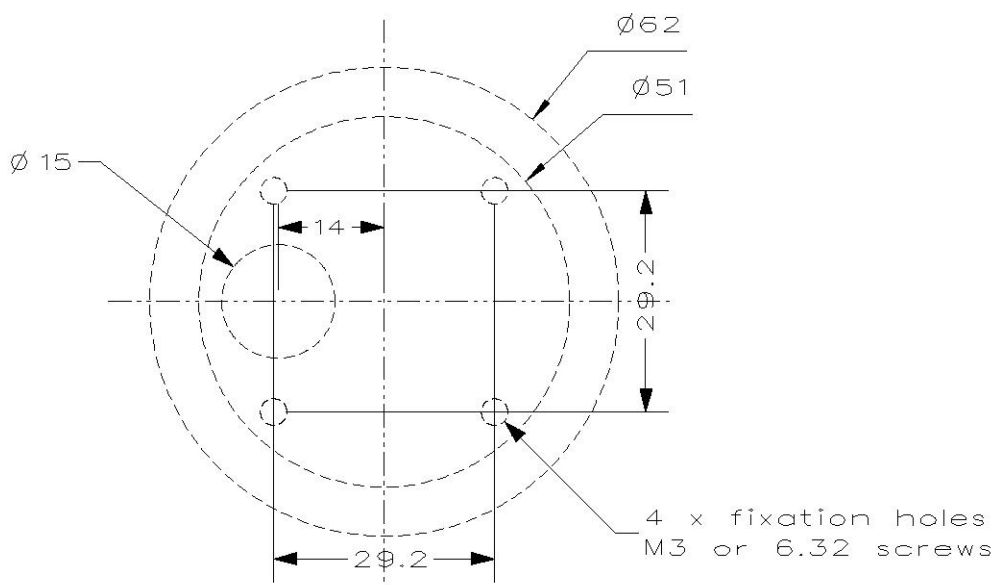

### 6.3 Limitation

Section 23 test not performed, only analysis provided.

No use it in the vicinity of thunderstorms or predicted thunderstorms, unless section 23 of ED-14 is considered as part of the installation.

## 7 Periodic Inspections

Every 100 hours or annually:

- Check that all Leds are illuminated.  
**WARNING:** Due to the high light intensity emitted by the equipment, it is recommended to wear eyes protection.  
In case of Leds failure, the equipment must be replaced or repaired (see documents reference "648 74 00 CMM 01" or "648 75 00 CMM 01" at the last issue into force).
- Check the lens aspect (absence of scratches or cracking). In case of presence of scratches or cracking on the glass, the equipment must be replaced or repaired (see documents reference "648 74 00 CMM 01" or "648 75 00 CMM 01" at the last issue into force).

Check the good state of the mechanical assembly and the electrical connections. In the case of a bad condition of the mechanical assembly or the electrical connection, they can be readjusted if they are not broken, otherwise the equipment must be replaced or repaired (see documents reference "648 74 00 CMM 01" or "648 75 00 CMM 01" at the last issue into force)

## 8 Annex 1 - 3D view

### 8.1 3D view (direct mounting with M5 Screw)

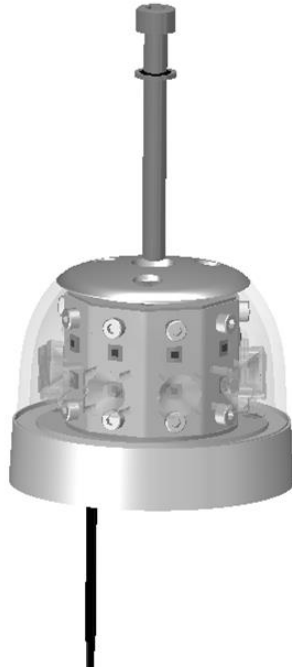

### 8.2 3D view with adaptation flange P/N 514 314

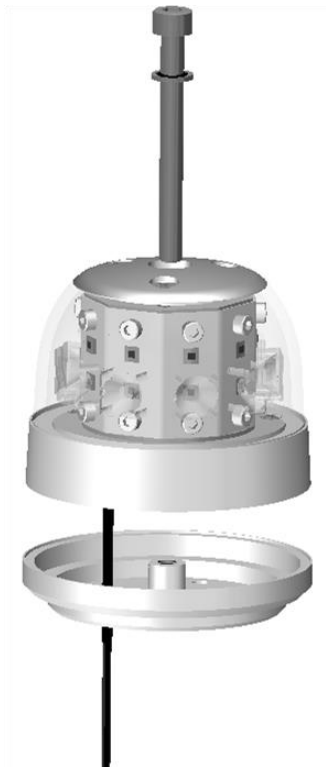

## 9 Annex 2 – 2D drawing

### 9.1 2D view (direct mounting with M5 Screw)

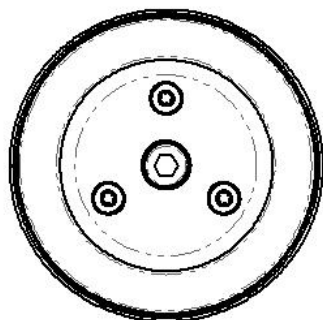
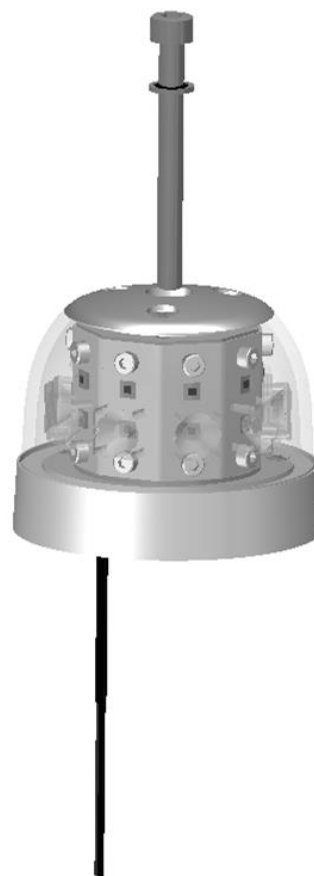
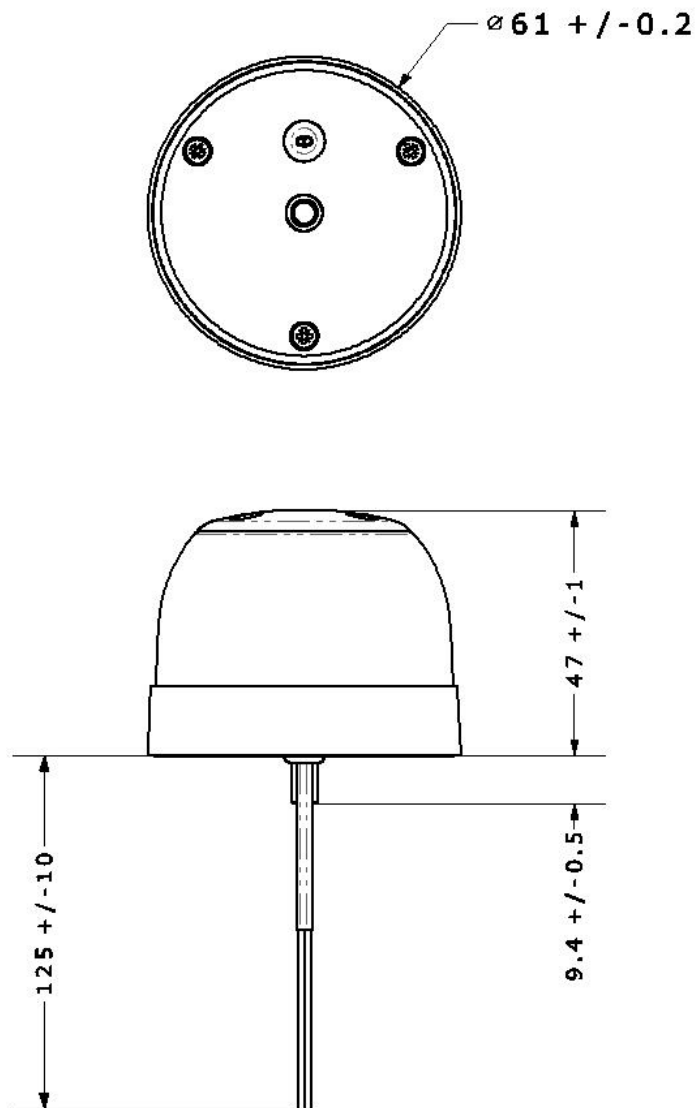

**9.2 2D view with adaptation flange P/N 514 314 for classic interface mounting**

