



# AIRCRAFT RED SHORT LED ANTICOLLISION LIGHT P/N 6487400 AMD(A)

## MAIN FEATURES - Aviation Red Short Led Anticollision Light

Certified CS ETSO C96b Class I (EASA.210.10075429 REV. A)

- **High reliability**

LED technology : more than 20 000 FH MTBF

- **Low EMI emission**

- **Light weight**

- **Resistance to high vibrations**

- **Tested for extreme environment**

## TECHNICAL FEATURES

- **Voltage:** 11 to 32 VDC- DO160G cat B

- **Power:** 20W peak / 6W Average

- **Flash per minute:** 48 +/- 5%

- **Lamp time ON :**

1st flash : 250 ms

2nd flash : 125 ms

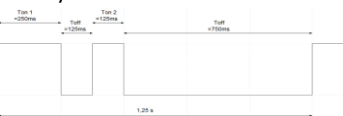

- **Light intensity:** >150 cd according to CS ETSO C96b Class I

- **Color:** Aviation Red

- **Operating Temperature :** - 45°C / +70°C

- **Electrical interface**

3 free end G22 wires: Red wire : +Vin

Black wire : 0V

White wire : Reduce mode (5%)

if linked at +Vin

- **Weight :**

Anticollision Light: 0.125 kg (0.281 pound) +/- 10%

Adaptation flange P/N 514314 (optional): 19g +/- 10%

Adaptation flange P/N 514317 (optional): 35g +/- 10%

- **Mechanical interface:** See 2D drawing

Fixation by central CHC M5x50 Inox A2 screw (included), or with adaptation flange (optional)

- **Mounting:** On fuselage or tail fin

Delivery with EASA Form One

## CONTACTS

- **Phone:** +33 (0)380 356 390,

- **Fax:** +33(0)380 356 100

- **Website:** www.jpcaviation.com

- **Email:** sales@jpcaviation.com



Direct mounting

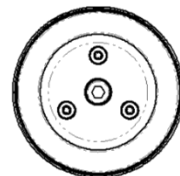
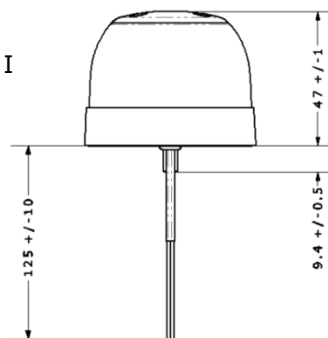
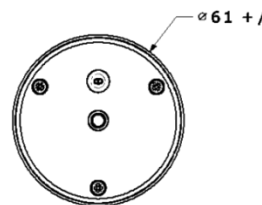

With adaptation flange

514317 + nut  
1 X 28.5 HOLE

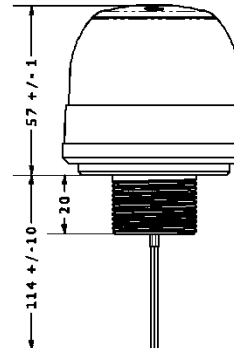
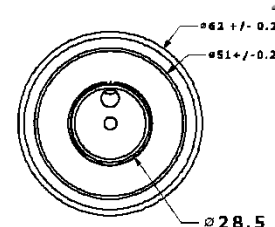

With adaptation flange

514314  
4 x 3.5 holes

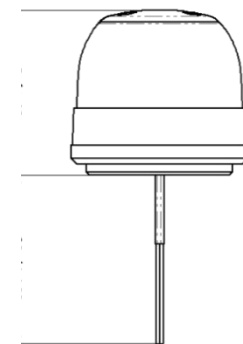
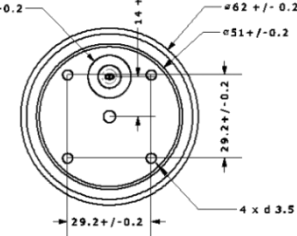

## EUROPEAN TECHNICAL STANDARD ORDER (ETSO) AUTHORISATION

### EASA.210.10075429 REV. B

This European Technical Standard Order (ETSO) Authorisation is issued by EASA, acting in accordance with Regulation (EU) 2018/1139 on behalf of the European Union, its Member States and of the European third countries that participate in the activities of EASA under Article 129 of that Regulation, subject to conditions specified below, to

#### J.P.C. AVIATION

AERODROME DE DIJON DAROIS  
21121 DAROIS  
FRANCE

in accordance with Commission Regulation (EU) No. 748/2012, Part 21, Section A, Subpart O and ETSO C96b  
for

Short LED Anticollision Light

P/N: 6487400 AMD(0), 6487500 AMD(0), 6487400 AMD(A), 6487500 AMD(A)  
DDP No. 648 74&75 00 DDP 01, ISSUE 9

#### Remarks:

This authorisation supersedes approval EASA.210.10075429 rev A , dated 12.09.2023, to remove limitations after additional tests. Issue 4 of the DDP 848 74&75 00 DDP 01 is the DDP valid for part numbers 6487400 AMD(0) and 6487500 AMD(0).

#### Deviations:

Use of category H instead of category A for DO-160 section 9 Explosion compliance demonstration.

#### Conditions:

1. The above ETSO Authorisation holder is only authorised to identify an Article with this ETSO marking whilst remaining in compliance with the conditions retained for the Issue of this Authorisation.
2. This ETSO Authorisation does not constitute an installation approval. It is the responsibility of those installing this article to determine that the aircraft installation conditions are within the ETSO standards.

This ETSO Authorisation shall remain valid until surrendered or revoked.

- End -

For the European Union Aviation Safety Agency  
Cologne, Germany, 22 September 2023



Francesco Maria CARIDEI  
Section Manager  
European Technical Standard Orders

#### Conditions:

1. The above ETSO Authorisation holder is only authorised to identify an Article with this ETSO marking whilst remaining in compliance with the conditions retained for the Issue of this Authorisation.
2. This ETSO Authorisation does not constitute an installation approval. It is the responsibility of those installing this article to determine that the aircraft installation conditions are within the ETSO standards.

This ETSO Authorisation shall remain valid until surrendered or revoked.

- End -