



AIRCRAFT XENON ANTICOLLISION LIGHT SYSTEM + NVG MODE P/N 6481101 & P/N 6480102

MAIN FEATURES - Aviation Red Anticollision Light system + NVG MODE Certified FAR27-FAR29 (Airbus Helicopters)

- **High reliability**

Power supply : 5000 FH MTBF

Xenon flash tube : 3.106 F @ 100 % cd

- **Low EMI emission**

- **Light weight**

- **Resistance to high vibrations**

Reinforced metallic clamp

- **Tested for extreme environment**

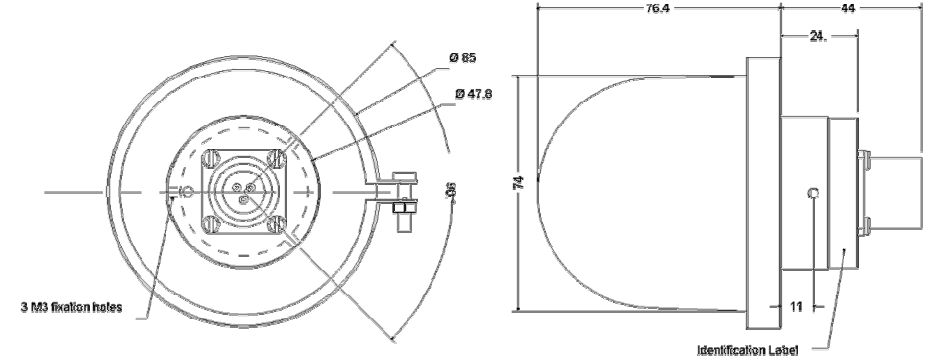

TECHNICAL FEATURES

- **Voltage :** 28 VDC- EN2282

- **Power:** 62W at 28V (Consumption 5A)

- **Flash per minute :** 42 FPM

- **Color:** Aviation red

- **Light intensity:** Anticollision mode: 150 cd according to FAR27/FAR29
NVG mode: 0.5 cd

- **Operating Temperature :** - 55°C / +85°C

- **Connector :** Light: MIL C 83723 K 12 03 PN

Power supply: MIL C 83723 K 12 03 PN

& MIL C 83723 K 12 03 P6

- **Weight :** Light: 0.450 kg (1 pound)

Power supply: 0.850 kg (1.87 pound)

- **Mechanical interface:** see 2D drawing

- **Mounting:** On fuselage or tail fin

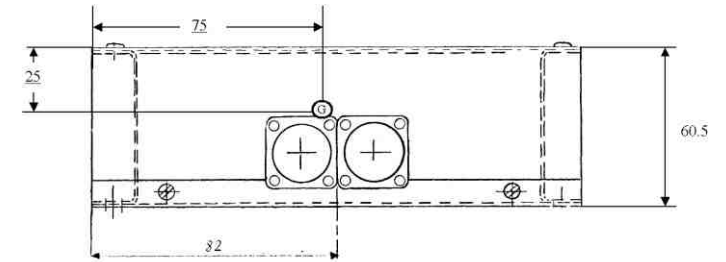

Delivery with EASA Form One

CONTACTS

- **Phone:** +33 (0)380 356 390,

- **Fax:** +33(0)380 356 100

- **Website:** www.jpccaviation.com

- **Email:** sales@jpccaviation.com

