



AIRCRAFT VOLTAGE REGULATOR 14V P/N 6141700 amd D

Main Features :

Aircraft charge voltage regulator including low voltage detection and overvoltage lock.

Certification: CS 23 (CEAPR, ROBIN AIRCRAFTS)

- Resistance to high vibrations
- Tested for extreme environment

Technical features:

- Input voltage: 14V
- Output max current (alternator excitation): 3A
- Regulation: from 13.5V to 13.75
- Discret output for warning light: if V < to 12.5V
- Overvoltage: Output locked if V > to 17V

- Operating temperature : - 45°C / +70°C
- Corrosion protection: SURTEC 650

- Electrical interface: (external connectors & pin provided)
AMP HE 15 mat n lock connector (5 point)

(old wiring)

- Point 5: red wire : + input from battery
- Point 4: black wire : - input from battery
- Point 3: blue wire : Output to alternator excitation
- Point 2: green wire : + input for warning light low voltage
- Point 1: white wire : + output for warning light low voltage

- Weight: 0.14 kg (0.315 pound)
- Interface mécanique: See 2D drawing
- Warranty: 2 years

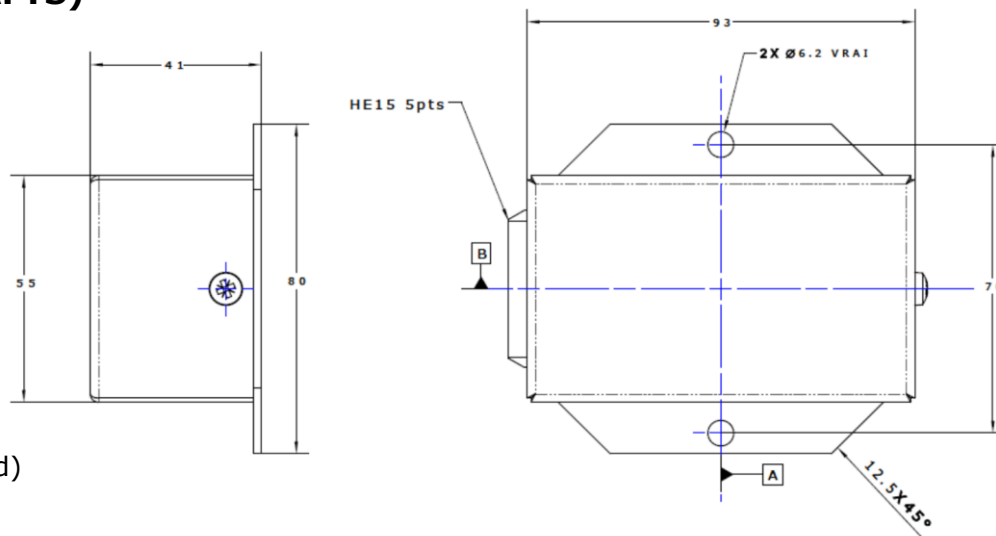

Contacts

- Phone : 03 80 35 63 90 Fax: 03 80 35 61 00
- Web site : www.jpccaviation.com Email: sales@jpccaviation.com